



# Quality Means High Reliability

## AerOpak<sup>®</sup> THERMOCOUPLES

For

High reliability applications

Special calibration limits for type K,  
J, E, T per ASTM E-230

High purity MgO insulation  
Metallic Sheath

Highest purity MgO insulation to  
yield maximum EMF stability and  
minimum drift problems caused by  
insulation impurities

Will manufacture specials to meet  
your requirements



**ARI** Industries Inc

**BULLETIN 1.0**

MAY 2001

# WIRE

## Termination Thermocouples STANDARD DESIGNS

**DESIGN NO. T-14** Lead wire termination with 1 inch bared wire.

**DESIGN NO. T-22** Potting adaptor with an extension of solid 20 ga. thermocouple lead wire, fiberglass over each and fiberglass over all, silicone varnish impregnated. The transition of AerOpak® to lead wire is capable of operation to 175°C.

**DESIGN NO. T-31** Potting adaptor with flex spring extension of solid 20 ga. thermocouple lead wire, fiberglass over each and fiberglass over all, silicone varnish impregnated. The transition of AerOpak® lead wire is capable of operation to 175°C.

**DESIGN NO. T-26** Potting adaptor with extension of solid 20 ga. thermocouple lead wire, fiberglass over each and fiberglass over all, silicone varnish impregnated. Stainless steel flexible tube placed over the lead wire to limit flexure and abrasion, transition of AerOpak to lead wire is capable of operation to 175°C.

**DESIGN NO. T-99** Potting adaptor with an extension of solid 20 ga. thermocouple lead wire, fiberglass over each and fiberglass over all, silicone varnish impregnated. Stainless steel braid over the lead wire to limit flexure and abrasion. Transition of AerOpak® to lead wire is capable of operation to 175°C.

Note: Lead wire terminations are approx. 16" (40.6cm) long, unless specified otherwise.

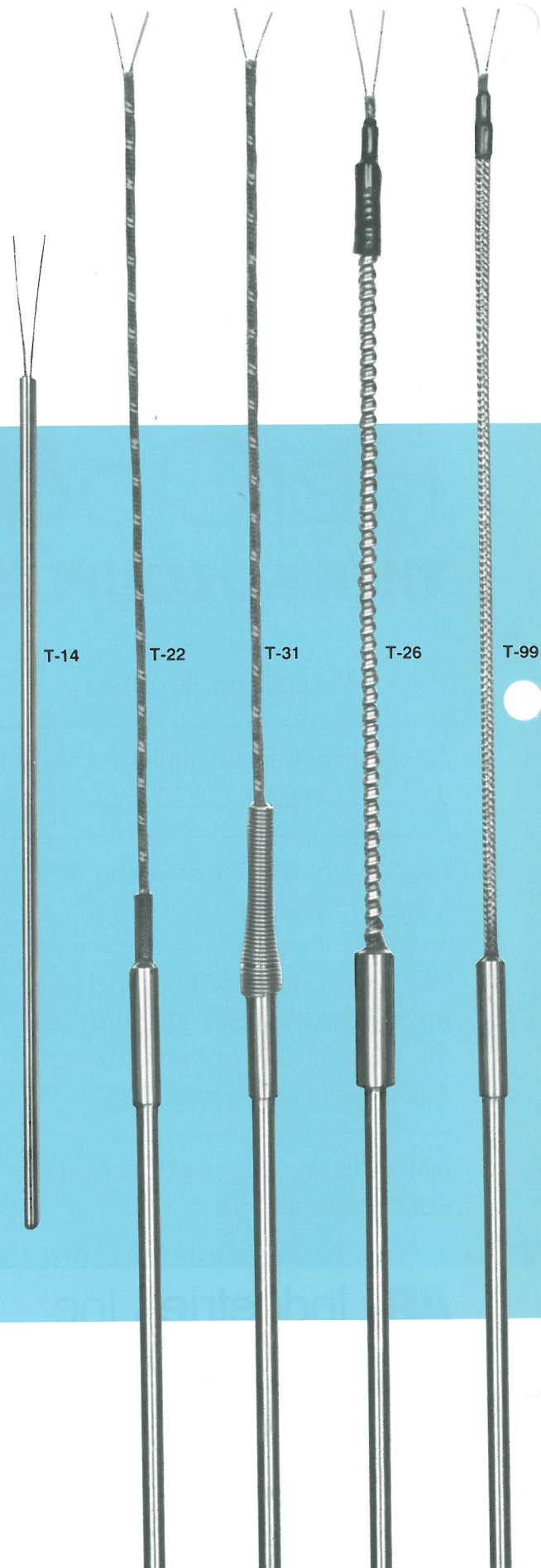

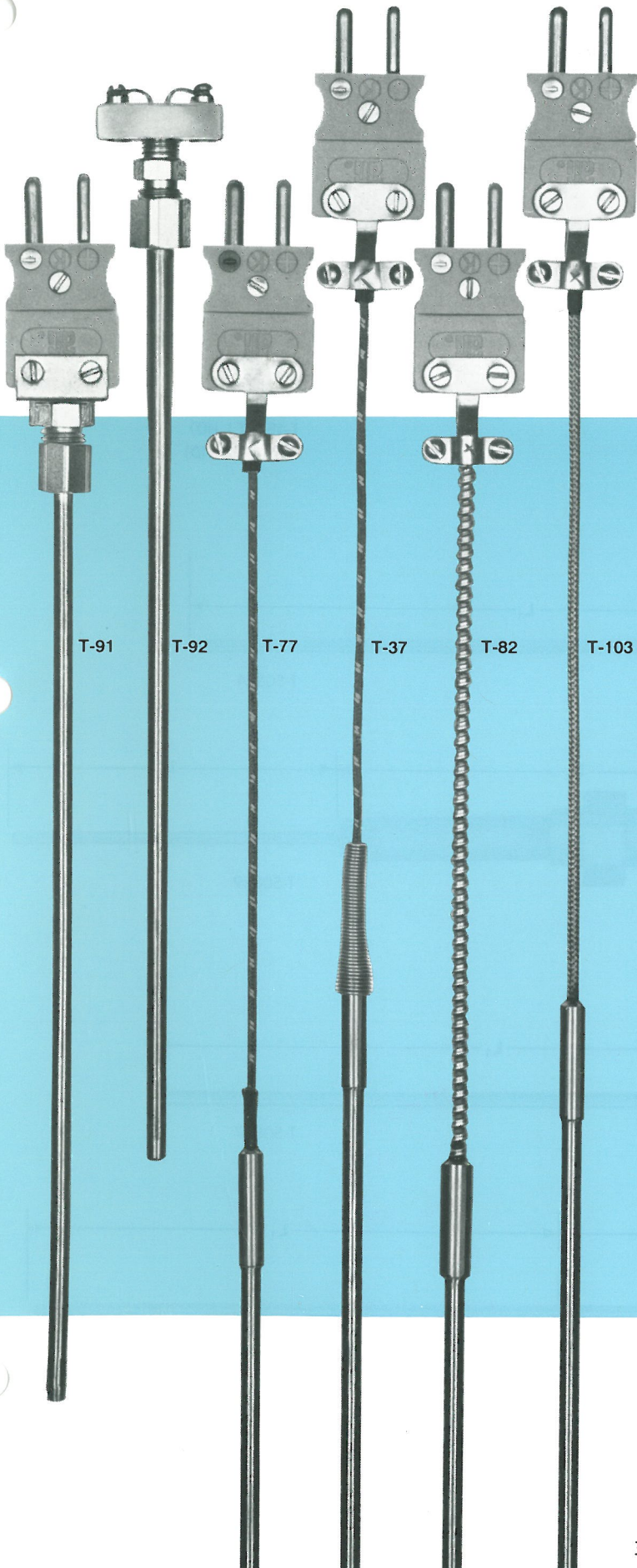

# PLUG

## Termination Thermocouples STANDARD DESIGNS

T-91

T-92

T-77

T-37

T-82

T-103

**DESIGN NO. T-91** Standard size male plug attached directly to the sheathed thermocouple.

**DESIGN NO. T-92** Ceramic connector terminal block attached directly to sheathed thermocouple.

**DESIGN NO. T-77** Potting adaptor with extension of solid 20 ga. thermocouple lead wire, fiberglass over each and fiberglass over all, silicone varnish impregnated. A standard size male plug attached to lead wire, transition of AerOpak® to lead wire is capable of operation to 175°C.

**DESIGN NO. T-37** Potting adaptor with flex spring extension of solid 20 ga. thermocouple lead wire, fiberglass over each and fiberglass over all, silicone varnish impregnated. A standard size male plug attached to lead wire, transition of AerOpak® to lead wire is capable of operation to 175°C with standard size male plug attached.

**DESIGN NO. T-82** Potting adaptor with an extension of solid 20 ga. thermocouple lead wire, fiberglass over each and fiberglass over all, silicone varnish impregnated. Stainless steel flexible tube placed over lead wire, transition of AerOpak® to lead wire is capable of operation to 175°C.

**DESIGN NO. T-103** Potting adaptor with an extension of solid 20 ga. thermocouple lead wire, fiberglass over each and fiberglass over all, silicone varnish impregnated. Stainless steel braid placed over the lead wire, with standard size male plug attached. Transition of AerOpak® to lead wire is capable of operation to 175°C.

HOW TO ORDER . . . see page 8

# CONNECTION HEAD

Termination Thermocouples  
STANDARD DESIGNS

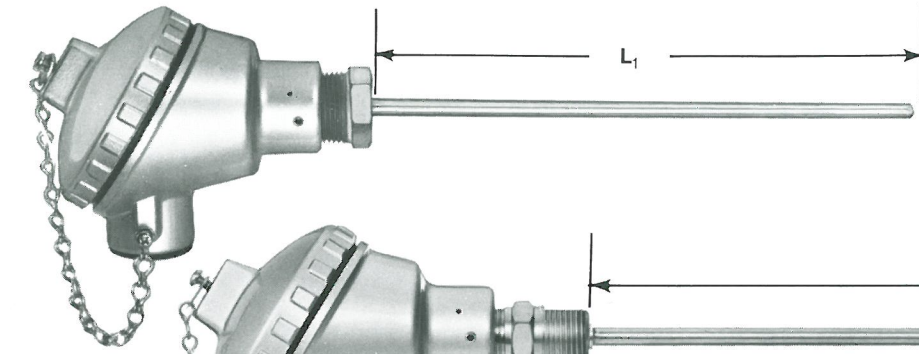

T-96 (C.A. HD)  
T-496 (C.I. HD)  
T-556 (C.E. HD)

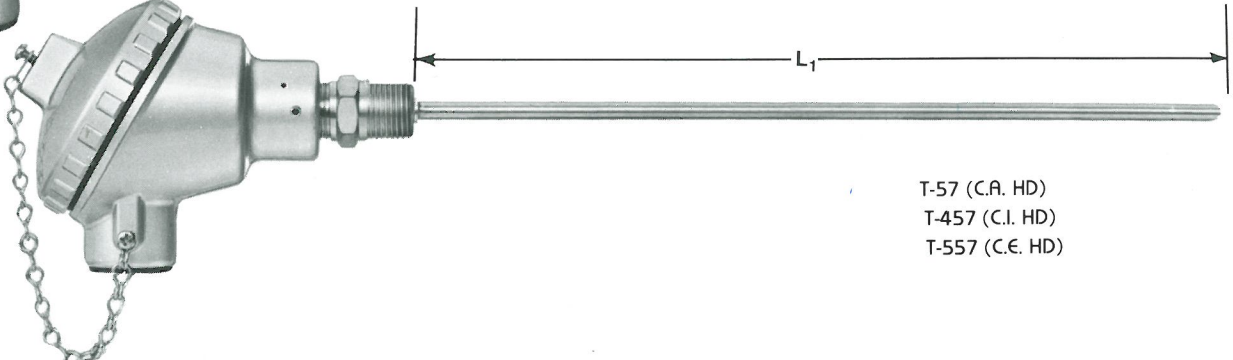

T-57 (C.A. HD)  
T-457 (C.I. HD)  
T-557 (C.E. HD)



T-50824



T-50829



T-50867



T-50271

HOW TO ORDER see page 8

**DESIGN NO. T-96** (CA) Connection head mounted directly on thermocouple.

**DESIGN NO. T-496** (CI) Connection head mounted directly on thermocouple.

**DESIGN NO. T-596** (CE) Connection head mounted directly on thermocouple.

**DESIGN NO. T-57** (CA) Connection head mounted directly on the thermocouple with 1/2" NPT Hex nipple mounting fitting.

**DESIGN NO. T-457** (CI) Connection head mounted directly on the thermocouple with 1/2" NPT nipple, mounting fitting.

**DESIGN NO. T-557** (CE) Connection head mounted directly on the thermocouple with 1/2" NPT Hex nipple mounting fitting.

**DESIGN NO. T-50824** Connection head assembly mounted directly on thermocouple with spring loaded 1/2" NPT Hex nipple mounting fitting.

**DESIGN NO. T-50829** Connection head with spring loaded terminal block mounted directly on thermocouple and 1/2" NPT nipple, union, nipple mounting hardware.

**DESIGN NO. T-50867** Connection head with spring loaded terminal block mounted directly on thermocouple with 1/2" NPT nipple for the mounting hardware.

**\*DESIGN NO. T-50271** Connection head with fixed terminal block and sanitary cap welded to the thermocouple.

\*Certified to the 3-A Sanitary Standards Symbol Council for Dairy Equipment.

## HEADS (HD)

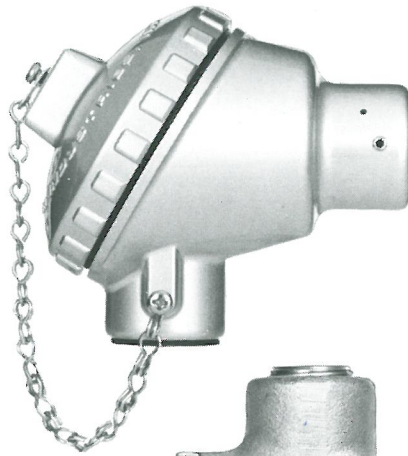

**CA** — Die Cast Aluminum with gray enamel coating.

**CI** — Cast Iron

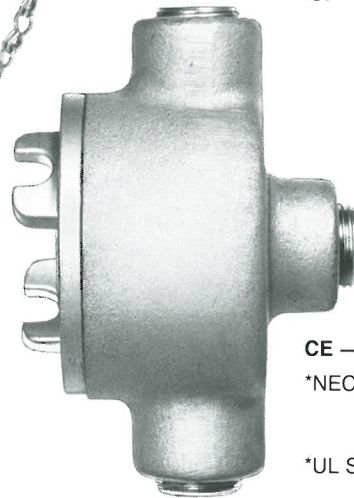

**CE** — Explosion Proof

\*NEC: Class I Groups C,D  
Class II Groups E,F,G  
Class III

\*UL Standard: 886

## TERMINATION BLOCK

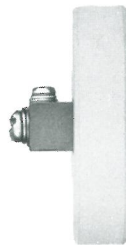

**FIXED CERAMIC BLOCK**  
with plated brass terminals.

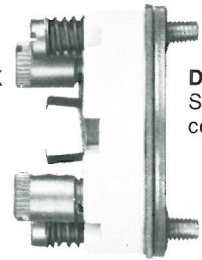

**DIN TYPE**  
Spring loaded ceramic block.

## INSERTS



T-14



T-0050867 & T-0050829



T-0096



T-0057



T-196

# MINIATURE

THERMOCOUPLE DESIGNS

**DESIGN NO. T-114** Lead wire termination with 1/2" bared wire.

**DESIGN NO. T-196** Miniature style connection head with fixed terminal block mounted directly to the thermocouple 1/4" exit threads.

**DESIGN NO. T-122** Potting adaptor with extension of solid 24 ga. thermocouple lead wire with fiberglass over each and fiberglass over all, silicone varnish impregnated. The transition of AerOpak® to lead wire is capable of operation to 175°C.

**DESIGN NO. T-131** Potting adaptor with flex spring an extension of solid 24 ga. thermocouple lead wire with fiberglass over each and fiberglass over all, silicone varnish impregnated. The transition of AerOpak® to lead wire is capable of operation to 175°C.

**DESIGN NO. T-177** Potting adaptor with an extension of solid 24 ga. thermocouple lead wire with fiberglass over each and fiberglass over all, silicone varnish impregnated. With miniature size male plug attached to lead wire. Transition of AerOpak® to lead wire is capable of operation to 175°C.

**DESIGN NO. T-137** Potting adaptor with flex spring and extension of solid 24 ga. thermocouple lead wire with fiberglass over each and fiberglass over all, silicone varnish impregnated. Miniature size male plug attached to lead wire. Transition of AerOpak® to lead wire is capable of operation to 175°C.

**DESIGN NO. T-191** Miniature plug connector attached to thermocouple.

**Note: HOW TO ORDER SEE PAGE 8.**

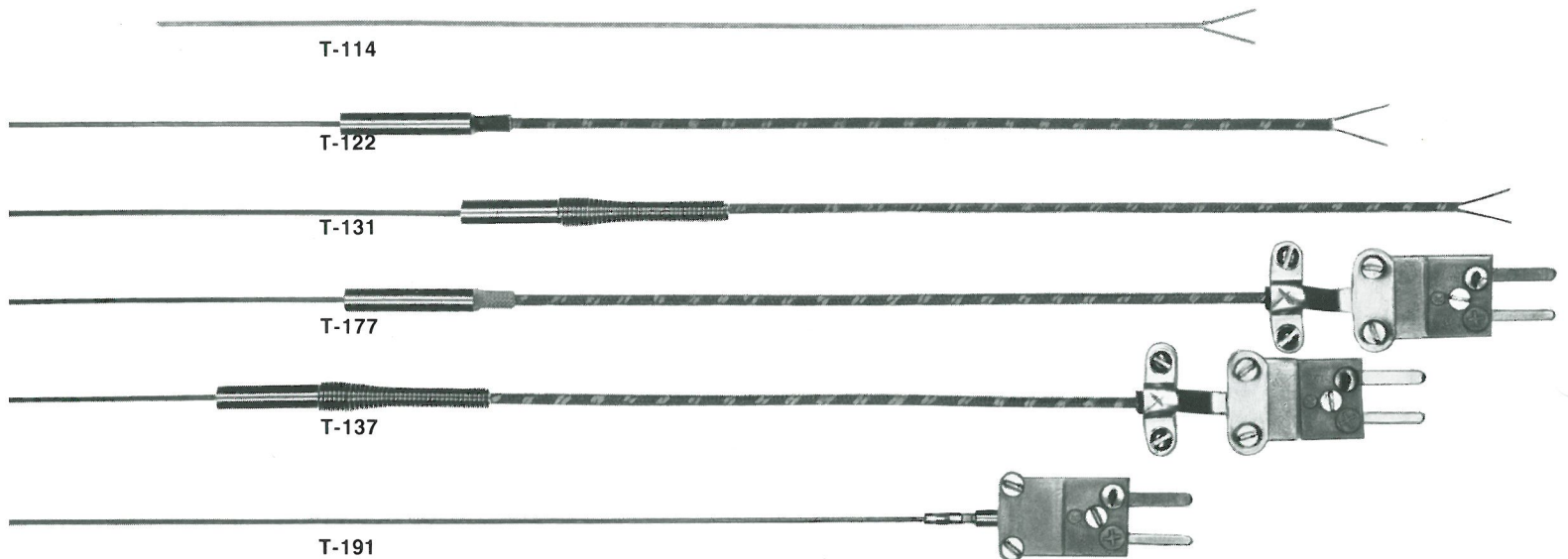

T-114

T-122

T-131

T-177

T-137

T-191

# SPECIFICATIONS

## TABLE 1 SHEATH & WIRE DIAMETER

ARI SYMBOL		L	A	B	D	E	F	G	I	K	P	R
SHEATH DIAMETER	inch	.020	.040	.062	.125	.188	.250	.313	.375	.500	.625	.750
	mm.	.50	1.00	1.67	3.17	4.75	6.35	8.00	9.52	12.7	15.9	19.1
WIRE DIAMETER	inch	.004	.006	.010	.020	.032	.040	.051	.064	.091	.114	.120
	mm.	.10	.15	.25	.50	.85	1.00	1.45	1.63	2.31	2.90	3.05
MAX. LENGTH	feet	30	200	290	290	135	81	45	30	30	20	13
	meters	9	61	88	88	41	25	14	9	9.1	6.1	4.0

## TABLE 2 WIRE CALIBRATION SPECIAL LIMITS OF ERROR

CALIBRATION	ARI SYMBOL	ASTM E-230 SYMBOL	APPROXIMATE SIMILAR CALIBRATIONS
*Chromel P-Alumel (1)	KS	K	BS 1827, DIN 43710, NFE 18-001, JIS-C1602
*Iron-Constantan	JS	J	BS 1829, NFE 18-001
*Chromel P-Constantan (1)	ES	E	—
*Copper Constantan	TS	T	BS 1828, DIN 43710, NFE 18-001, JIS-C1602

\*Calibrations are to special limits of error

(1) Registered T.M. of Hoskins Mfg. Co.

## TABLE 3 HOT JUNCTION SYMBOLS

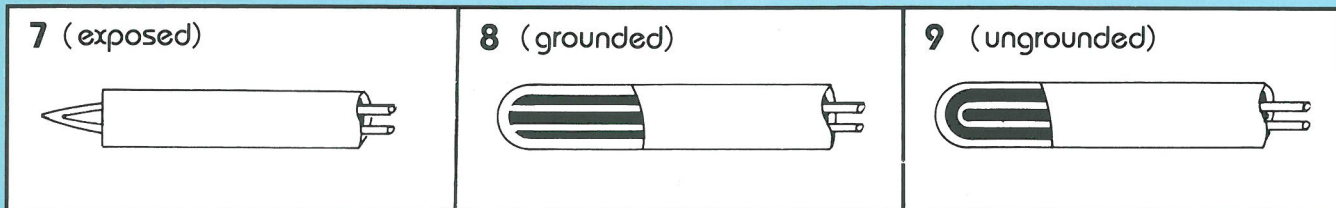

## TABLE 4 SHEATH MATERIAL

SHEATH	ARI SYMBOL	MELTING POINT		USEABLE TEMP. IN AIR		EQUIVALENT ANALYSIS
		°F	°C	°F	°C	
AISI 347 ST/ST	F	2550	1400	1650	900	BS 3605 832Nb; DIN 4550; UNS S34700
Inconel 600 (3)	B	2570	1410	2100 (1)	1150	BS 3074-NA14; DIN 4816; UNS NO6600
AISI 304 ST/ST	A	2550	1400	1650 (2)	900	BS 3605-801; DIN 4301; UNS S30400
AISI 310 ST/ST	D	2570	1410	2100	1150	BS 3605-805; DIN 4878; UNS S31000
AISI 316 ST/ST	C	2550	1400	1650	900	BS 3605-845; DIN 4401; (2-3% Mo); UNS S31600
HASTELLOY X	V	2470	1355	2200	1222	TM CABOT CORP.

(1) Not recommended for use in sulfur atmosphere

(2) Do not use in 800 to 1600°F temperature range due to carbon intergranular precipitation

(3) Trademark of International Nickel Corp.

## TIME CONSTANTS

SHEATH DIA.	Cond. A	Cond. B	Cond. C	Cond. D
5/16	0.5*	5.5	5.0	55.0
1/4	0.3	4.0	2.5	39.0
3/16	0.2	2.5	2.0	26.0
1/8	0.1	1.5	1.0	14.0
1/16	0.05	0.5	0.5	5.0
.040	0.01	0.3	0.1	2.5

\*Time in seconds

Some typical time constants (time for the thermocouple temperature to reach 63.2% of a step change in gas or liquid temperature) for various sizes are listed for different media.

Cond. A: No. 7 hot junction in water moving at a velocity ( $V_0$ ) of 1.5m/sec. (5 ft/second).

Cond. B: No. 8 hot junction in water moving at a velocity ( $V_0$ ) of 1.5m/sec. (5 ft/second).

Cond. C: No. 7 hot junction in air moving at a mass velocity ( $G_0$ ) of 29.3 Kg/sec. m<sup>2</sup> (6 lbs/sec. ft.<sup>2</sup>)

Cond. D: No. 8 hot junction in air moving at a mass velocity ( $G_0$ ) of 29.3 Kg/sec. m<sup>2</sup> (6 lbs/sec. ft.<sup>2</sup>)

For time constants ( $\tau$ ) at other velocities ( $V$ ) or mass velocities ( $G$ ) use the equations below:

$$\tau = \tau_0 \sqrt{\frac{V_0}{V}} \quad (\text{for liquids})$$

$$\text{or } \tau = \tau_0 \sqrt{\frac{G_0}{G}} \quad (\text{for gases})$$

The results of these equations will be affected by using liquids other than water and gases other than air. However, the effect is small and can be neglected for many applications.

**INSULATION MATERIAL:** Symbol "N" 99.4% min. High Purity MgO meeting requirements of ASTM E-585 and E-608. Impurities minimized to yield maximum EMF stability, minimum drift problems.

**LEAD WIRE LENGTH:** 16 inch (40 cm) long normally supplied. If longer lengths are required designate in Part Number.

**SHEATH LENGTH "L":** Specified in inches in even increments of length from 2.54 cm (1 inch) to 88 meters (3465 inches). See Table 1 for maximum length for each diameter. Length tolerances to be:  $\pm 3.2$  mm ( $\pm 1/8$  in.) up to 30.5 cm (12 in.);  $\pm 8.0$  mm ( $\pm 5/16$  in.) up to 244 cm (96 in.);  $\pm 50.8$  mm ( $\pm 2$  in.) over 244 cm (96 in.).

**INSULATION RESISTANCE:** 100 megohms or more @ 500 V DC for lengths of 15 meters (50 feet) or less for 1.67 to 8.0 mm (1/16 to 5/16") diameter. 10 megohms or more @ 1 1/2 V DC for lengths of 15 meters (50 feet) or less for 1.0 and .63 mm (0.04 and 0.025") diameters. This measurement is made prior to fabrication of hot junction.

**BEND INSULATION RESISTANCE:** Minimum insulation resistance, after bending around a mandrel whose diameter is 4 times, the sheath diameter, to be 2.5 megohms @ 1 1/2 V DC.

**HIGH TEMPERATURE INSULATION RESISTANCE:** ALL AEROPAK thermocouple of lengths of 61 cm (24") or less will have a minimum insulation resistance of 10,000 ohms or more at 1 1/2 V DC at 1000°C (1800°F).

**AVAILABILITY:** 2 Wire (1 T/C circuit) sheath diameters: .50 to 19.1 mm (.020 to .750 inch).  
4 Wire (2 T/C circuit) sheath diameters: 3.17 to 19.1 mm (.125 to .750 inch). Exposed, grounded, and ungrounded hot junction.

**SPECIAL SPECIFICATIONS:** To specific customer specifications, or to Nuclear grade requirements, i.e.:  
MIL-T-23234A RDT C7-6T ASTM E-235 ASTM E-585 E-608  
with complete testing per above specifications within ARI facilities.

**PRESSURE RATING:** AEROPAK® thermocouples using No. 8 or 9 hot junction are pressure tight to 3500 Kg/cm<sup>2</sup> (50,000 psi) at temperatures up to 649°C (1200°F). AEROPAK thermocouples using No. 7 junction are pressure tight to 350 Kg/cm<sup>2</sup> (5000 psi) if a seal is used at the cold end.

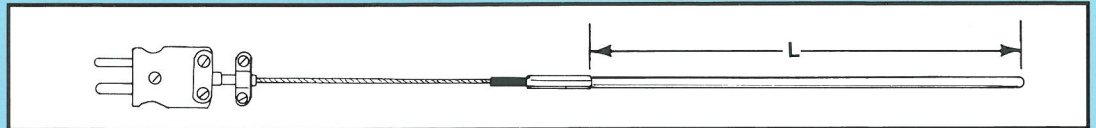

**Example: Catalog No. T-77 N-6 D (KS) 8 F 16**

A B C D E F G H

- A Design No. — (See page 2, T-77 in this example)
- B Insulation Material — Symbol "N" (99.4% min MgO purity)
- C Sheath Length "L" in inches — (6 inches in this example)
- D Sheath Diameter Symbol — (See Table 1; 1/8" in this example)
- E Wire Calibration Symbol — (See table 2; chromel-alumel; special limits of error in this example)
- F Junction Style Number — (See table 3; grounded in this example)
- G Sheath Material Symbol — (See table 4; 347 ST/ST in this example)
- H Length of Lead Wire — If other than 16" please specify.

Note: When duplex circuit required add (.4) after the design number. For example: a (T-77N) in duplex circuit would be (T-77.4N)

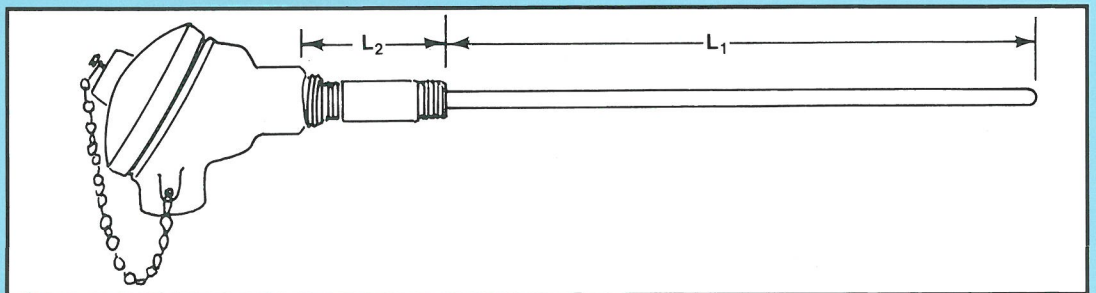

**Example: Catalog No. T-50867 N-6 F (KS) 8 A (CA) 3**

A B C D E F G H I

- A Design No. — (See page 4) T-50867 in this example.
- B Insulation Material — Symbol "N" (99.4% min MgO Purity)
- C Sheath Length "L" in inches — (6 inches in this example)
- D Sheath Diameter Symbol — (See table 1; 1/8" in this example)
- E Wire Calibration Symbol — (See table 2; chromel-alumel; special limits of error in this example)
- F Junction Style Number — (See table 3; grounded in this example)
- G Sheath Material Symbol — (See table 4; 347 ST/ST in this example)
- H Type of Connection Head — (See page 5) Die Cast aluminum in this example
- I Length of Nipple — (L<sub>2</sub>)

Note: When duplex circuit required add (.4) after the design No. For example: a (T-50867N) in duplex circuit would be (T-50867.4N).

## HOW TO ORDER WIRE & PLUG ASSEMBLIES:

(Pages 2, 3 and 6)

## HOW TO ORDER CONNECTION HEAD ASSEMBLY:

(Pages 4 and 5)



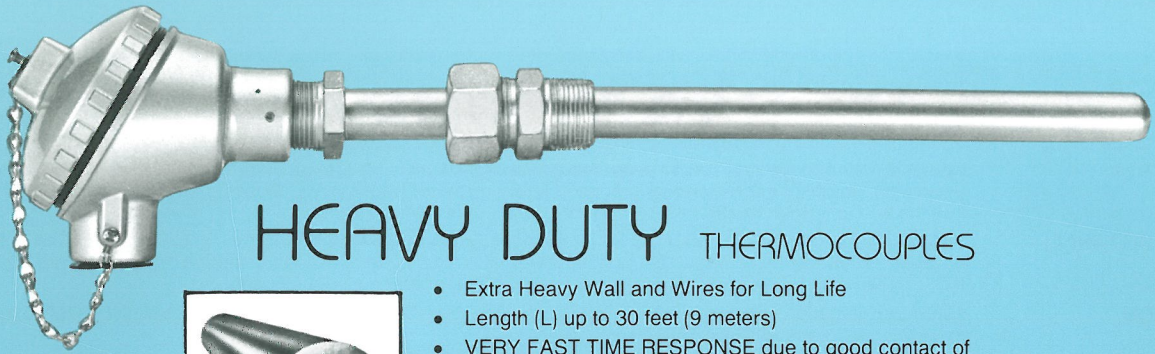

## HEAVY DUTY THERMOCOUPLES

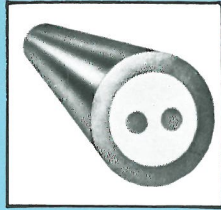

- Extra Heavy Wall and Wires for Long Life
- Length (L) up to 30 feet (9 meters)
- VERY FAST TIME RESPONSE due to good contact of wires with outer sheath
- Adaptable to corrosive atmospheres
- Easy to remove and reinstall into process line
- Available from stock with Inconel 600, 310 ST/ST and 316 ST/ST sheath and with calibration K wires. Other sheaths and calibrations are also available.



## TEMPERATURE TRANSMITTER

2 Wire (4-20 MA) THERMOCOUPLES

2 Year Transmitter Warranty

- Fits into a waterproof screw cap Connection Head. Eliminates the requirements for separate junction box and mounting.
- Available for Thermocouple type calibration J, K, E, and T.
- RFI and EMI protected.
- Available with spring load thermocouple assemblies.

BULLETIN 6.3

## HIGH TEMPERATURE THERMOCOUPLES

ARi Industries offers time tested thermocouples for temperature measurement in ULTRA HIGH TEMPERATURES beyond the useable range for base metal thermocouples.

The material combinations listed in the following tables have been carefully selected to make use of desirable properties, for a common sense approach to an otherwise difficult selection process. Each element, insulation and sheath combination is listed for the temperature range or environment least likely to result in short term failures, extending reliable temperature measurement to the 4000°F range. Inert gas backfilling prior to reduction is available on request. This extra step may be performed on either the compacted insulation "AerOpak®" approach or non-compacted protection tube styles.

Bulletin 2.0, 2.2, 2.3

## SPECIAL APPLICATION THERMOCOUPLES

ARi Industries, Inc. has a complete line of thermocouples for special applications. Our Engineering Department is staffed by graduate and experienced engineers, competent in mechanical, electrical, and metallurgical aspects of design. Do not hesitate to contact us for your special requirements.

---

**WELDING PAD  
THERMOCOUPLES**

---

Tube surface assemblies  
Bulletin 3.0

---

**MULTIPOINT  
THERMOCOUPLES**

---

Multipoint assemblies  
Bulletin 7.3

---

**RTD'S**

---

High Impact & vibration resistant RTD's  
Bulletin 8.0

---

**HEATERS**

---

M.I. Cable Heaters  
Bulletin 5.0

---

**WIRE & CABLE**

---

MgO Insulated Cable  
Bulletin 4.0, 4.1

---

**HIGH TEMPERATURE  
THERMOCOUPLES**

---

High Temperature &  
Industrial 3000°F Thermocouples  
Bulletin 2.0, 2.2, 2.3

---

**TRANSMITTERS**

---

Temperature Transmitter Systems  
Bulletin 6.2, 6.3

---

**HARDWARE**

---

Thermocouple Hardware & Accessories  
Bulletin 6.0

---

Thermowells  
Bulletin 6.1

---

OTHER **ARi** PRODUCTS

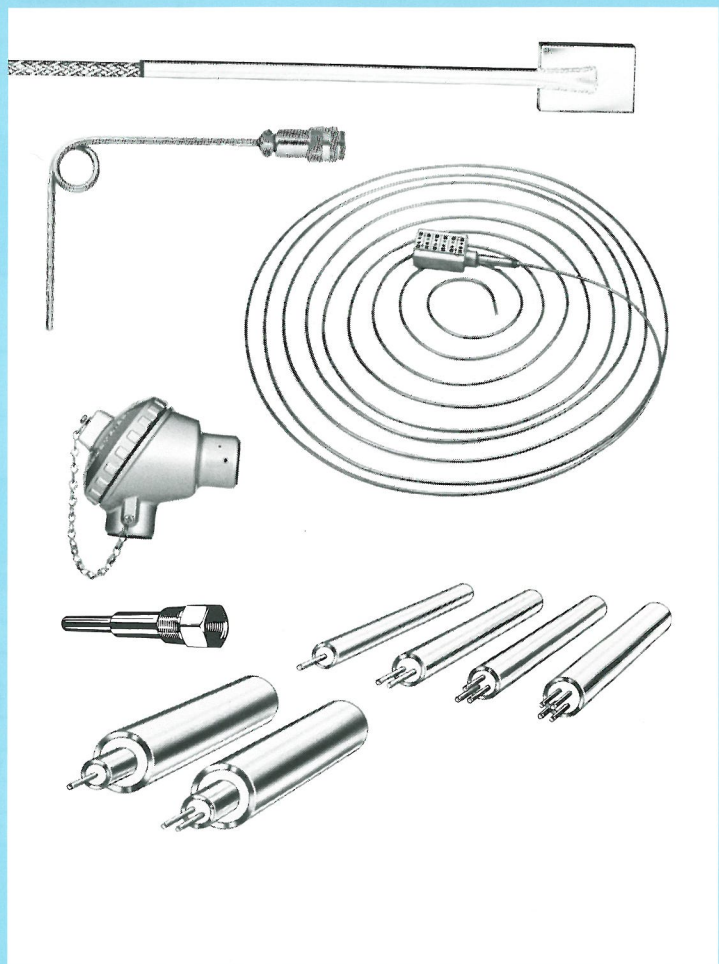

381 ARi Court, Addison, IL 60101 USA  
Phone: 630-953-9100  
Telefax: 630-953-0590

**TOLL FREE 1-800-AEROPAK (1-800-237-6725)**

E-mail: [sales@ariindustries.com](mailto:sales@ariindustries.com)  
Website: [www.ariindustries.com](http://www.ariindustries.com)

**Contact your Local ARi Representative:**